

**30cm 2 zone induction cooktop with Pause function, QuickCook Timer and touch slide controls.**  
RRP AUS \$1,349.00

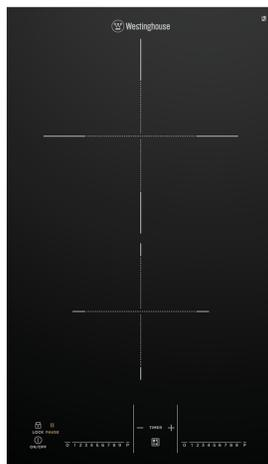

## Product Details

### FEATURES

---

PowerBoost

Touch slide control

Pause

QuickCook Timer

---

Perfect heat control

Easy cleaning

Residual heat indicator

Child safety device

---

### BENEFITS

---

#### Zero to Boil in no time

With PowerBoost, you can rapidly boil a pot of water or quickly heat up a frying pan. Spend less time waiting and more time creating your favourite meals.

#### Slide for instant temperature control

Easy touch slider control allows you to choose your temperature setting instantly with the slide of a finger.

---

#### Hold everything with our clever Pause function

We know that family life is full of distractions. That's why you'll appreciate our clever Pause function. Simply touch the Pause icon on your cooktop and all operating induction zones will drop to Keep Warm mode. When you're ready to go again, hit Pause again and settings will return to where you left off.

#### Timed to perfection

Never over-cook or burn dinner again. Just set the cooking time and your cooktop will automatically turn the heat off for you.

---

# Specifications

## PRODUCT PROFILE

Domestic warranty details (yrs)	2
Cooktop type	induction
Materials/Colour	black ceramic glass

## CONTROLS

Controls of Cooktops	Touch and Slide controls
Position of controls	front
Functions of Cooktops	timer,Keep warm function,pause,PowerBoost
Indicators/display	fault indicator,residual heat warning lamps
Features of Cooktop	safety cut off,electronic timer,safety child lock,hot surface indicator
Timer of Cooktop	programmable 99min,countdown

## DIMENSIONS

Total product height (mm)	46
Total product width (mm)	300
Total product depth (mm)	520
Cut out width (mm)	270
Cut out depth (mm)	490

## ELEMENTS/BURNERS

### CENTRE FRONT ZONE

Centre front zone	induction
Centre front Watts	1400
Centre front number of cooking zones	1
Centre front diameter mm	140

## CONTROLS

---

Readable temperature setting    No

---

## CENTRE REAR ZONE

---

Centre rear zone                    induction

---

Centre rear Watts                    2300

---

Centre rear number of cooking zones                    1

---

Centre rear diameter mm                    210

---

## SHIPPING

---

Shipping Weight (Kg)                    6

---

Pack Dimensions Height (mm)                    110

---

Pack Dimension Width (mm)                    390

---

Pack Dimension Depth (mm)                    600

---

## ELECTRICAL SPECIFICATIONS

---

Connected load KW                    3.7

---

Type of connection                    hardwired

---

## STUFFING QUANTITIES

---

20ft                    880

---

40ft HC                    2024

---

# Dimensions

## 30cm induction cooktop

WHI323BC

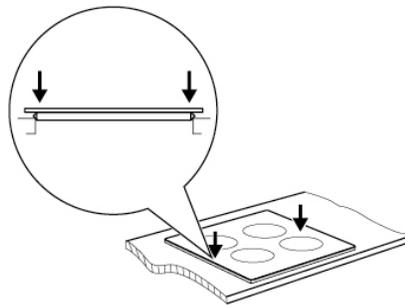
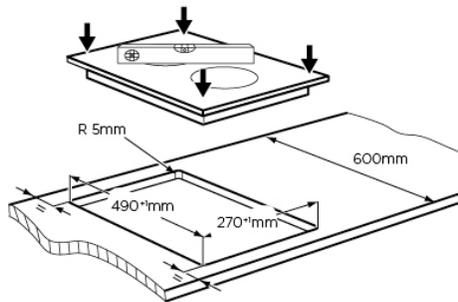

**i** **IMPORTANT**

It is recommended to centre the bench cutout with equal distance front and back as shown but the product has also been certified to be installed with no clearance between the rear edge of the cooktop glass and rear wall if required. In doing so, installers still need to leave sufficient clearance to take into account that the glass dimensions are larger than the cut out.

**IMPORTANT**

These dimensions are a guide only. All measurements are in millimetres (mm). For complete installation instructions, refer to the manual provided with product.

# Terms and Conditions

## IMPORTANT

This is a guide of product dimensions only. For complete installation instructions, refer to the manual provided with product.

## PRODUCT INFORMATION

The descriptors and illustrations in this publication apply to the specific products and models described as at the date of issue. Under our policy of continuous product development, product specifications may change without notice. Prospective purchasers should therefore check with their retailer to ensure this publication correctly describes the products that are being offered for sale. All information supplied is to be used for general reference purposes only and is on the understanding that Electrolux Home Products Pty Ltd (Australia) and Electrolux (NZ) Ltd (New Zealand) will not be liable for any loss, liability or damage of whatever kind arising as a result of reliance on such information. Colours of products illustrated are as close as printing limitations allow. Electrolux will at all times comply with its obligations pursuant to law including Trade Practices (Australian Consumer Law) Act and Regulations.

## WARRANTY

This warranty only applies to Appliances purchased and used in Australia or New Zealand and used in normal domestic applications and is in addition to (and does not exclude, restrict, or modify in any way) any non-excludable statutory warranties in Australia or New Zealand. All warranties are subject to the conditions set out in the warranty card accompanying the product when purchased.

### ELECTROLUX HOME PRODUCTS AUSTRALIA

telephone: 1300 363 640

fax: 1800 350 067

email: [customercare@electrolux.com.au](mailto:customercare@electrolux.com.au)

web: [www.electrolux.com.au](http://www.electrolux.com.au)

### ELECTROLUX HOME PRODUCTS NEW ZEALAND

telephone: 09 573 2230

fax: 09 573 2221

email: [customercare@electrolux.co.nz](mailto:customercare@electrolux.co.nz)

web: [www.electrolux.co.nz](http://www.electrolux.co.nz)